

# IMS- MC1200-9TB Track Conveyor

IMS have added to their extensive range of track conveyors by offering a twin feed hopper track conveyor that can offer multiple operational advantages to the mining, quarry and construction industry. The MC1200-9TB offers two 5.5 meter (17'8") long feed hoppers with the capacity of 12 cubic meter per hopper large enough to accommodate the larger size loaders and the hopper capacity to insure that the material feed does not run out before the return of the loader. Both feed hoppers have front control flow gates and variable speed conveyors to offer controlled flow for blending of two products or combined 24 cubic meters of a single product to enable high production, the large hopper capacity is especially relevant when conveying light weight product such as wood chips and pellets.

With such a large Feed Hooper capacity and a 1200mm meter wide main conveyor belt the MC1200-9TB can offer production up to 1000 tonnes per hour ensuring affordable blending costs and the capacity to operate as a feeder to high production ship loaders and stockpilers etc. The MC1200-9TB has a 4.772 meter (15'6") high conveyor belt for stockpiling and high enough to add fines or blending mix is to the fines belt of a standard mobile screen under a controlled basis and the feed hopper large enough that the machine can be left along for long periods while the loader undertakes other duties, if a problem does arrive the loader can simply stop the feed with the remote stop/start. The conveyor can work in variable heights including horizontal.

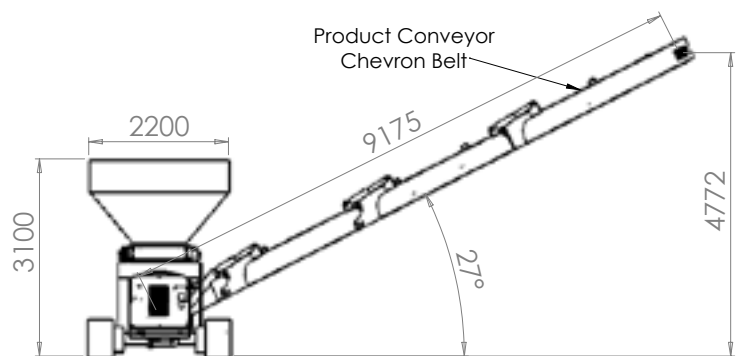
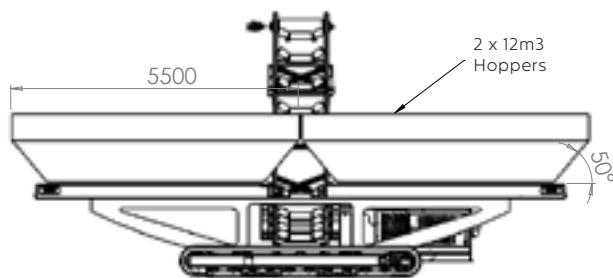
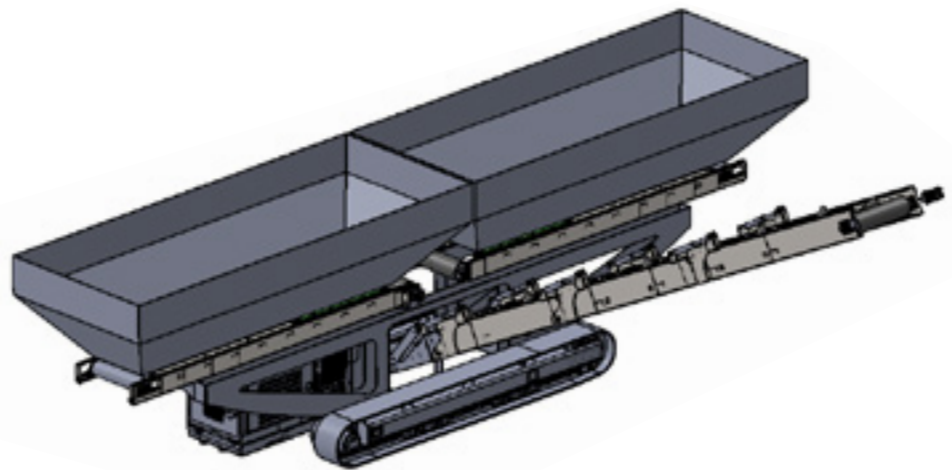

WORKING MODE

The MC1200-4TB has the same specifications but fitted with a shorter 4 meter long conveyor to undertake operations such as filling in drains on the move and laying out compost and materials in windrows for drying and blending. Once again the 24 meter hopper capacity minimises downtime and reloading cycles.

**John Andersen +61(0)424 181 056 | Chris Wong +61(0)424 180 860**

Fax: +61(0)7 3036 6400 | Email: [info@crusherscreen.com](mailto:info@crusherscreen.com) | [www.crusherscreen.com](http://www.crusherscreen.com)

Crusher and Screen Sales PTY Ltd | ABN: 55 150 600 418 Gold Coast QLD 4220 | PO Box 144 Southport QLD 4215

- High Capacity
- Blending
- Windrowing
- Filling In Of Drains
- Stockpiling
- Feed Hopper Transfer

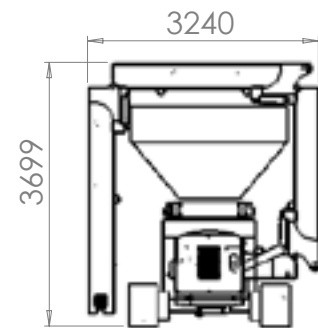
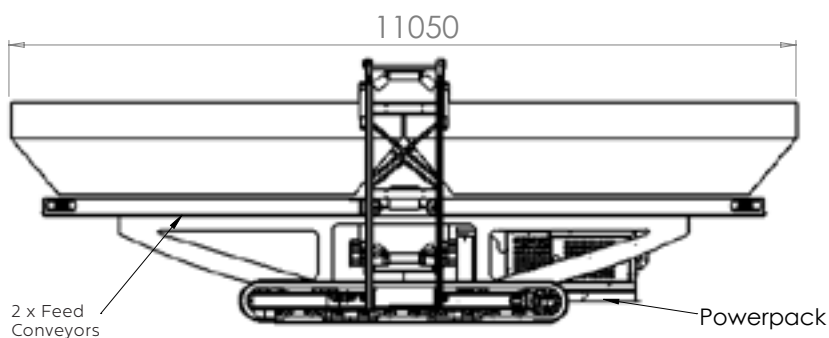
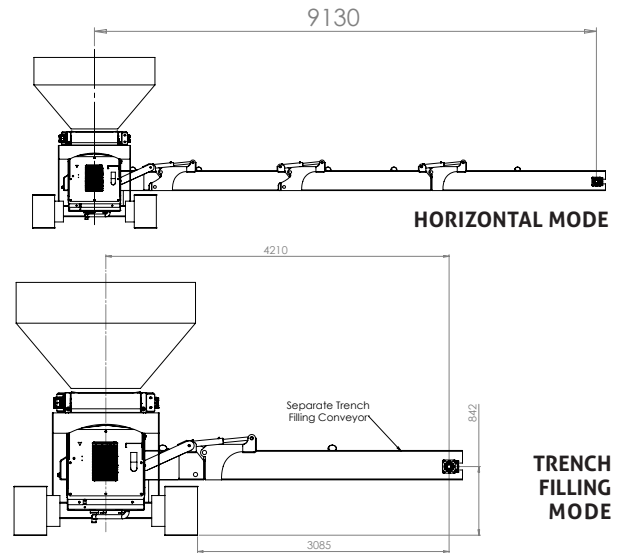

**TRANSPORT MODE**

The **MC1200-9TB Track Conveyor** offers the advantage of site management with total mobility between production operations, reducing down time of moving skid mounted hoppers and conveyors, reducing the possibility of safety hazards and the reduction of loader movements. If operating multiple sites it is just a matter of folding over the conveyor and loading onto a transport. The Track Conveyor has the option of twin power with the ability to connect to mains power. A more affordable wheel vision with electric mains power connection is available.

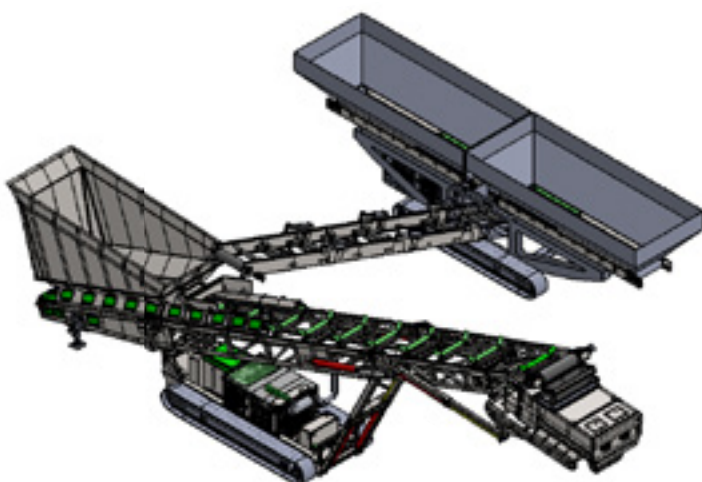

Drawing shows the **MC1200-9TB** working in conjunction with the **IMS - PM1050-16TB Pugmill**, offering another two products to blend with the pugmill's own **12 M3 product feed hopper** material.